

SkyLine Chills Blast Chiller-Freezer 20GN2/1 150/120 kg - Remote for CO2

ITEM # _____

MODEL # _____

NAME # _____

SIS # _____

AIA # _____

725166 (EBFA22LRECO)

Skyline Chills Blast Chiller Freezer 150/120kg, 20 GN 2/1 or 600x400mm with touch screen control and remote refrigerating Unit, CO2 with valve

Short Form Specification

Item No.

- Blast chiller freezer with high resolution full touch screen interface, multilanguage
- For GN, 400x600 or Banqueting trolleys.
 - Load capacity: chilling 150 kg; freezing 120 kg
 - OptiFlow air distribution system to achieve maximum performance
 - Chilling/Freezing modes: Automatic (10 food families with 100+ different pre-installed variants); Programs (a maximum 1000 programs can be stored and organized in 16 different categories); Manual (soft chilling, hard chilling, freezing, holding, turbo cooling and lite hot cycles); Specialistic Cycles (Cruise chilling, fast thawing, Sushi&Sashimi, Sous-Vide chilling, ice-cream)
 - Special functions: MultiTimer chilling/freezing, Make-it-Mine to customize interface, SkyHub to customize homepage, agenda MyPlanner, SkyDuo connection to SkyLine ovens
 - Remaining time estimation for probe-driven cycles based on artificial intelligence techniques (ARTE 2.0)
 - Automatic and manual defrosting and drying
 - USB port to download HACCP data, programs and settings. Connectivity ready
 - 3-point multi sensor core temperature probe
 - Stainless steel construction throughout
 - Internal rounded corners
 - Remote refrigeration unit (optional accessory).
 - Specific for CO2 gas
 - Performance guaranteed at ambient temperatures of +43°C (Climatic class 5)
 - Compatible with Electrolux, Zanussi and Rational ovens.

Main Features

- Freezing cycle: 120 kg from 90°C up to -41°C.
- Blast Chilling cycle: 150 kg from +90°C up to + 3°C.
- X-Freeze cycle: ideal for blast freezing all kinds of food (raw, half or fully cooked).
- Lite-Hot cycle: ideal for soft heating preparations.
- Holding at +3 °C for chilling or -22 °C for freezing, automatically activated at the end of each cycle, to save energy and maintain the target temperature (manual activation is also possible).
- Turbo cooling: chiller works continuously at the desired temperature; ideal for continuous production.
- Automatic mode including 10 food families (meat, poultry, fish, sauces and soup, vegetables, pasta/ rice, bread, savory and sweet bakery, dessert, beverage fast cooling) with 100+ different pre-installed variants. Through Automatic Sensing Phase the blast chiller optimizes the chilling process according to size, quantity and type of food loaded to achieve the selected result. Real time overview of the chilling parameters. Possibility to personalize and save up to 70 variants per family.
- Cycles+:
 - Cruise Chilling (Patented EP1716769B1 and related family) automatically sets the parameters for the quickest and best chilling (it works by probe)
 - Fast Thawing
 - Sushi&Sashimi (anisakis-free food)
 - Sous-vide chilling
 - Ice Cream
- OptiFlow air distribution system to achieve maximum performance in chilling/heating evenness and temperature control thanks to a special design of the chamber.
- Programs mode: a maximum of 1000 programs can be stored in the blast chiller's memory, to recreate the exact same high standard at any time. The programs can be grouped in 16 different categories to better organize the menu. 16-step chilling programs also available.
- MultiTimer function to manage up to 20 different chilling cycles at the same time, improving flexibility and ensuring excellent results. Can be saved up to 200 MultiTimer programs.
- 3-point multi sensor core temperature probe for high precision and food safety.
- Remaining time estimation for probe-driven cycles based on artificial intelligence techniques (ARTE 2.0 Patented US7971450B2 and related family) for an easier planning of the activities.
- Automatic and manual defrosting and drying.
- Performance guaranteed at ambient temperatures of +43°C (Climatic class 5).

Construction

- Remote refrigeration unit (optional accessory).
- Solenoid valve to automatically manage the gas pressure in the thermodynamic circuit.
- Main components in 304 AISI stainless steel.
- Evaporator with antirust protection.

APPROVAL: _____

- Motors and fan waterproof protected IP23.
- Hygienic internal chamber with all rounded corners for easy cleaning.
- Removable magnetic gasket door with hygienic design.
- Ventilator swinging hinged panel for access to the evaporator for cleaning.
- Automatic heated door frame.

User Interface & Data Management

- High resolution full touch screen interface (translated in more than 30 languages) - color-blind friendly panel.
- Pictures upload for full customization of cycles.
- Make-it-mine feature to allow full personalization or locking of the user interface.
- SkyHub lets the user group the favorite functions in the homepage for immediate access.
- With SkyDuo the Oven and the Blast Chiller are connected to each other and communicate in order to guide the user through the cook&chill process optimizing time and efficiency (requires optional accessory).
- MyPlanner works as an agenda where the user can plan the daily work and receive personalized alerts for each task.
- USB port to download HACCP data, share chilling programs and configurations.
- Connectivity ready for real time access to connected appliances from remote and HACCP monitoring (requires optional accessory).
- Trainings and guidances supporting materials easily accessible by scanning QR-Code with any mobile device.
- Automatic consumption visualization at the end of the cycle.

Sustainability



- Human centered design with 4-star certification for ergonomics and usability.

Optional Accessories

- Kit of 3 single sensor probes for blast chiller/freezers PNC 880567
- Pair of AISI 304 stainless steel grids, GN 1/1 PNC 922017
- AISI 304 stainless steel grid, GN 1/1 PNC 922062
- AISI 304 stainless steel grid, GN 2/1 PNC 922076
- Pair of AISI 304 stainless steel grids, GN 2/1 PNC 922175
- AISI 304 stainless steel bakery/pastry grid 400x600mm PNC 922264
- IoT module for OnE Connected (Combi Ovens, Blast chiller/freezers, Rack Type DW) and SkyDuo (one IoT board per appliance - to connect oven to blast chiller for Cook&Chill process). PNC 922421
- Connectivity router (WiFi and LAN) PNC 922435
- SkyDuo Kit - to connect oven and blast chiller freezer for Cook&Chill process. The kit includes 2 boards and cables. Not for OnE Connected PNC 922439
- Trolley with tray rack, 15 GN 2/1, 84mm pitch PNC 922686
- Spit for lamb or suckling pig (up to 30kg) for 20 GN 2/1 ovens PNC 922711
- Probe holder for liquids PNC 922714
- Trolley with tray rack 20 GN 2/1, 63mm pitch PNC 922757
- Trolley with tray rack, 16 GN 2/1, 80mm pitch PNC 922758
- Banquet trolley with rack holding 92 plates for 20 GN 2/1 oven and blast chiller freezer, 85mm pitch PNC 922760
- Bakery/pastry trolley with rack holding 400x600mm grids for 20 GN 2/1 oven and blast chiller freezer, 80mm pitch (16 runners) PNC 922762
- Banquet trolley with rack holding 116 plates for 20 GN 2/1 oven and blast chiller freezer, 66mm pitch PNC 922764

Front

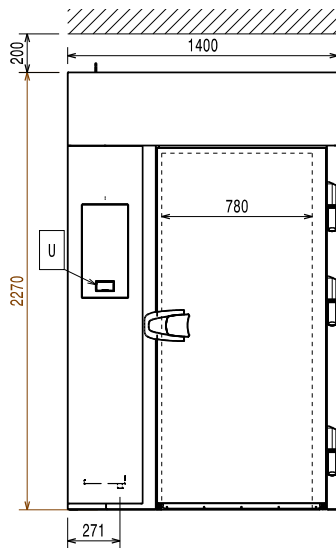

Side

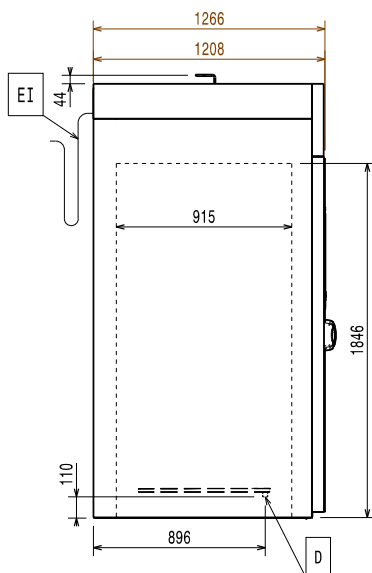

EI = Electrical inlet (power)
 RO = Refrigerant Outlet

Distances

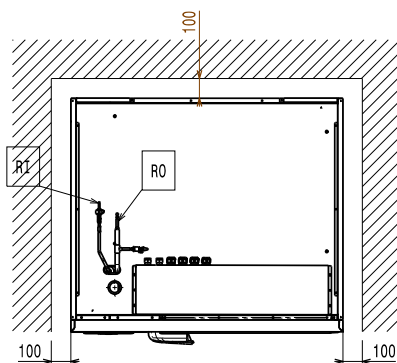

Electric

Circuit breaker required

Supply voltage: 380-415 V/3N ph/50/60 Hz

Heating power: 6.4 kW

Water:

Drain line size:

Pressure, bar min: 0

Installation:

Clearance: 5 cm on sides and back.

Capacity:

Max load capacity: 150 kg

Number and type of grids: 20 (GN 2/1; 600x400)

Number and type of basins: 30 (360x250x80h)

Key Information:

Door hinges: Right Side

External dimensions, Width: 1400 mm

External dimensions, Depth: 1266 mm

External dimensions, Height: 2270 mm

Net weight: 180 kg

Shipping weight: 190 kg

Shipping volume: 4.81 m³

Refrigeration Data

Condenser cooling type:

Suggested refrigeration power: 8070 W

Condition at evaporation temperature: -20 °C

Condition at condensation temperature: 40 °C

Condition at ambient temperature: 30 °C

Connection pipes (remote) - outlet: 12 mm

Connection pipes (remote) - inlet: 22 mm

Compatible refrigerant gas: R744

ISO Certificates

ISO Standards: ISO 9001; ISO 14001; ISO 45001; ISO 50001